

PRODUCT TECHNICAL SHEET

Collection : **PLUG**

Ref. : **4570.--.26**

Mitigeur cuisine 2 trous, grand bec mobile 250 mm avec mousseur extractible, 1 jet

2-gats ééngreeps keukenmengkraan met grote beweegbare bek 250 mm en uittrekbare perlator, 1 straal

2-hole single lever kitchen mixer with great swing spout 250 mm and pull-out aerator, 1 spray

Picture



Product details

Flow at 3 bar : 8 l/min

Internal mechanism : Joystick ceramic cartridge (90°)

Note : Max 5 bars

Provide room for counterweight

Technical drawing

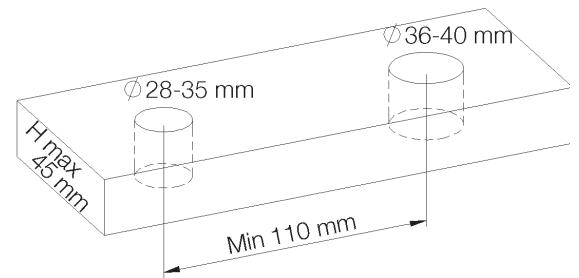
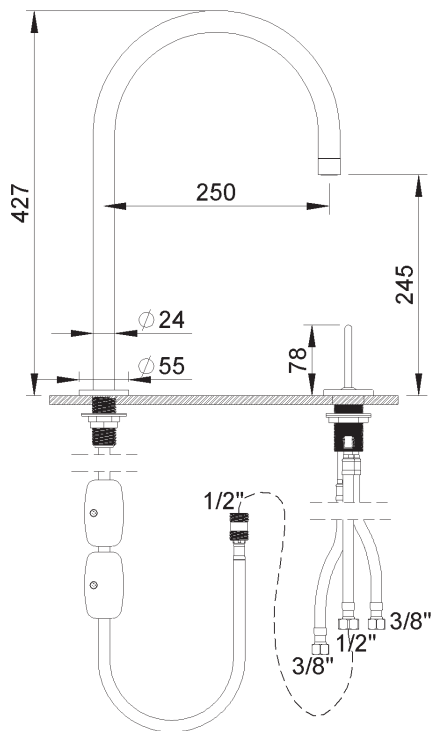

RA1.V01